

GENERAL SCHEME

Mod. L-80

SAUSAGE CUTTING MACHINE
GASER-MOD. L-80

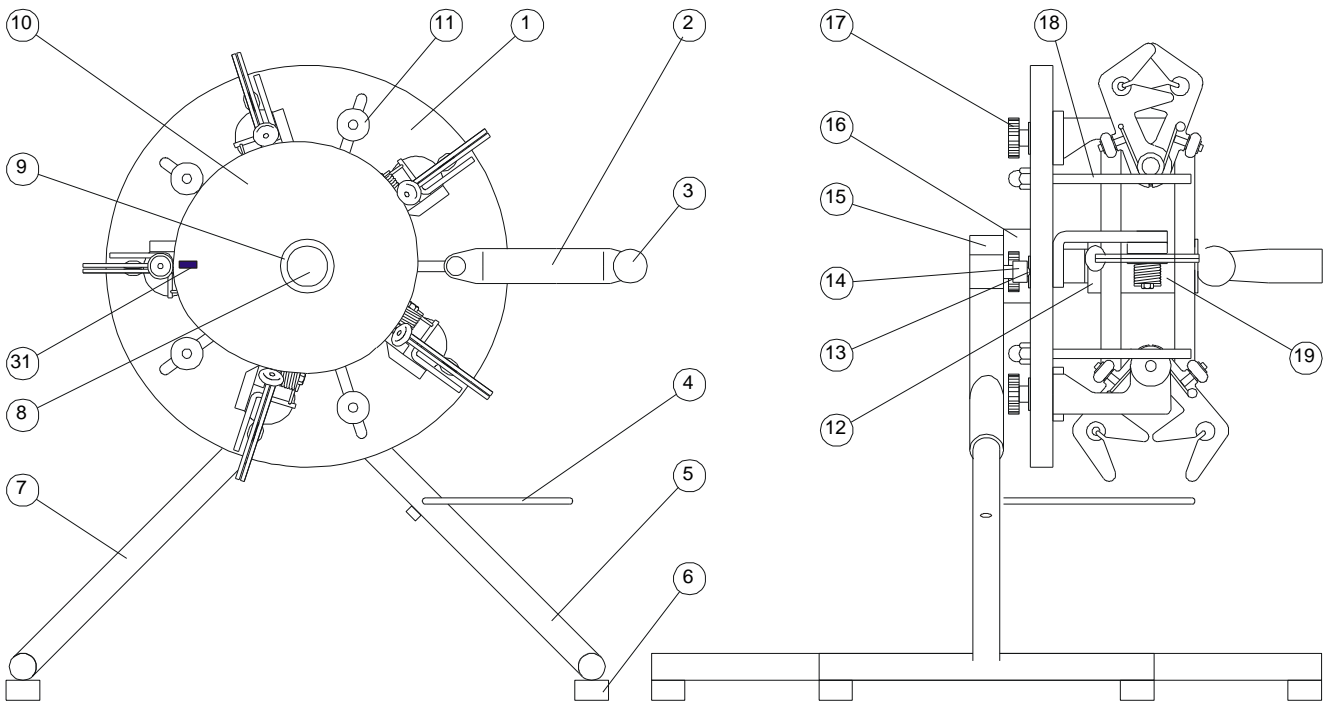

GENERAL SCHEME

Mod. L-80

CUTTING PINCERS UNIT

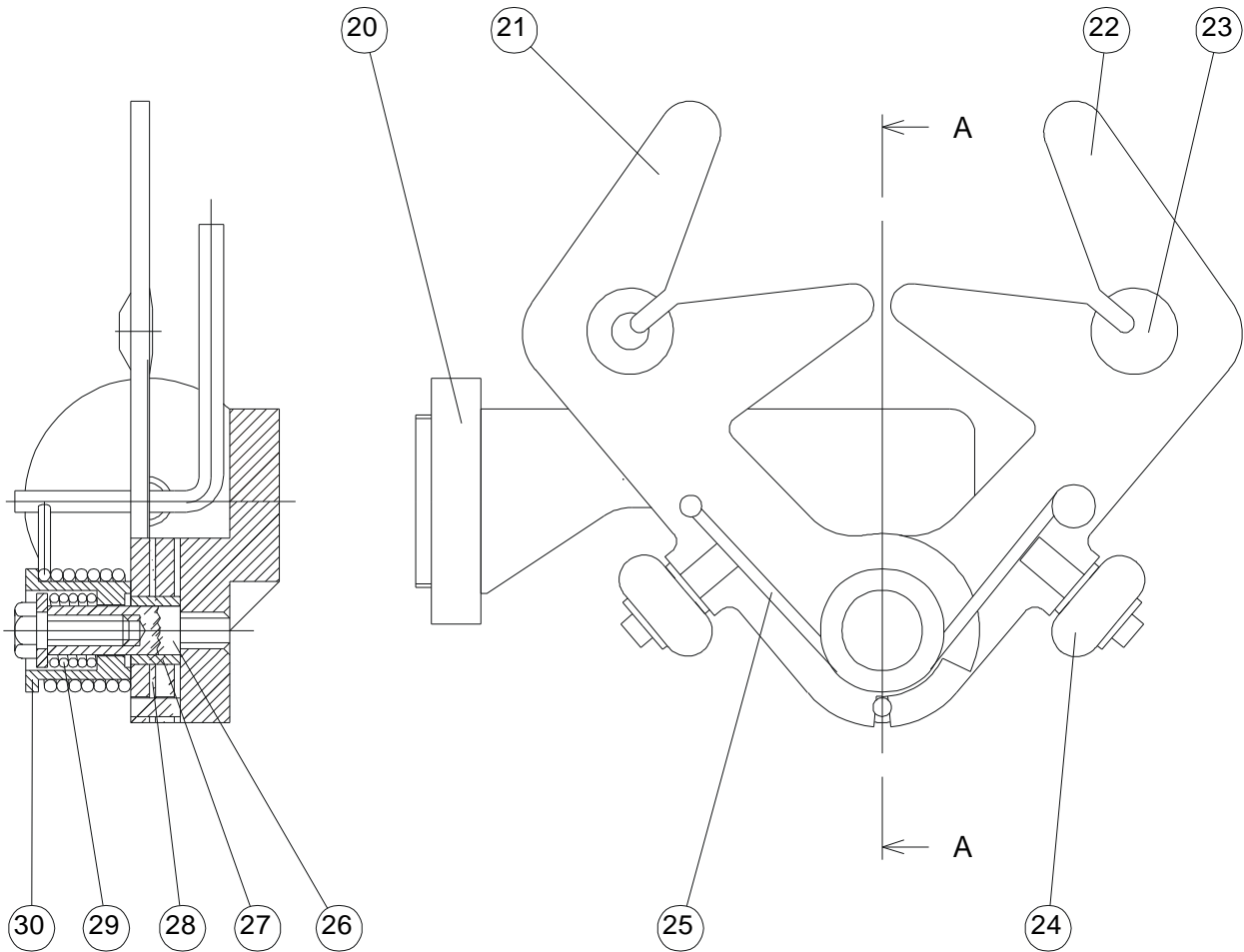

GENERAL SCHEME

Mod. L-80

1	Rotating plate
2	Crank unit
3	Crank handle
4	Guide rod of stuffing
5	Foot of long base
6	Rubber base
7	Foot of short base
8	Outer attachment bowl
9	Outer attachment washer
10	Eccentric
11	Attachment washer for rod of stuffing support
12	Attachment washer for eccentrics
13	Stainless steel bowl D-8
14	Rotating plate axle
15	Main support
16	Rotating plate support
17	Reeded nut to attach pincer unit
18	Support rod for stuffing
19	Separator of eccentrics
20	Pincers support
21	Inner cutting pincer
22	Outer cutting pincer
23	Blades
24	Wheel
25	Outer spring
26	Joint of pincers
27	Inner bronze sleeve
28	Washer for separating pincers
29	Interior spring
30	Sleeve of pincer joint
31	Position marker