

# ***KOLBE***



**MWK 32**



**MWK 114**

**MISCHWÖLFE MIXER GRINDER**

# Technische Daten • Technical Data

Mischwölfe	Mixer Grinder		MWK 32	MWK 114
Schneidsystem	Cutting system		Enterprise E32	Unger D114
Lochscheibendurchmesser	Plate diameter	mm	100	114
Trichtervolumen	Funnel volume	Ltr	45	45
Förderleistung bei 3 mm Lochscheibe	Hourly output with perforated disc of 3 mm	kg/h	950	950
Motorspannung (3Ph)	Motor tension (3Ph)	V	400	400
Motor - Hauptantrieb / Schutzart IP55	Motor - Main drive / Protection system IP55	kW	3,0	4,0
Motor - Mischantrieb / Schutzart IP55	Motor - Mixer drive / Protection system IP55	kW	0,37	0,37
Nennstrom bei 400 V - Hauptantrieb	Nominal current at 400 V - Main drive	A	7,1	9,1
Nennstrom bei 400 V - Mischantrieb	Nominal current at 400 V - Mixer drive	A	1,17	1,17
Leiterquerschnitt	Conductor size	mm <sup>2</sup>	2,5	2,5
Netzabsicherung bei 400 V (A träge)	Fusing at 400 V (A lazy)	A	16	16
Abmessungen B x T x H	Dimensions W x D x H	mm	635 x 879 x 1190	635 x 944 x 1190
Einfüllhöhe	Input height	mm	1133	1133
Gehäuseauslaufhöhe (mit Haube)	Lower housing height (with cover)	mm	575 (513)	518 (513)
Lärmpegel	Noise level	dB (A)	70	70
Gewicht netto	Weight net	kg	250 - 260	250 - 260

**MWK 32**

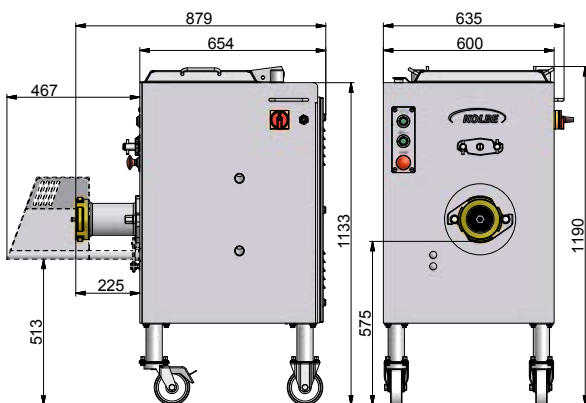

**MWK 114**

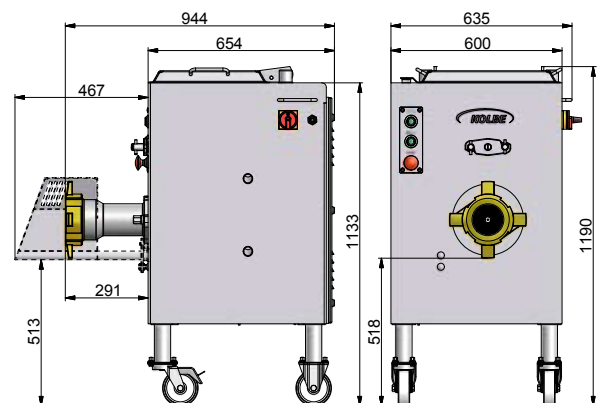

## Ausstattungsmerkmale und Vorteile • Features and benefits



**Schneidsystem Enterprise**  
Cutting system Enterprise



**Schneidsystem Unger**  
Cutting system Unger



**Mischtrichter mit Autoreversefunktion**  
Mixing unit with autoreverse function



**Auslaufschutzhaube**  
Outlet protection